

Pfiffner Hydromat® HB 45/12, HB 32/16, HB 32-45/16

Flexible Rotary Transfer Machines

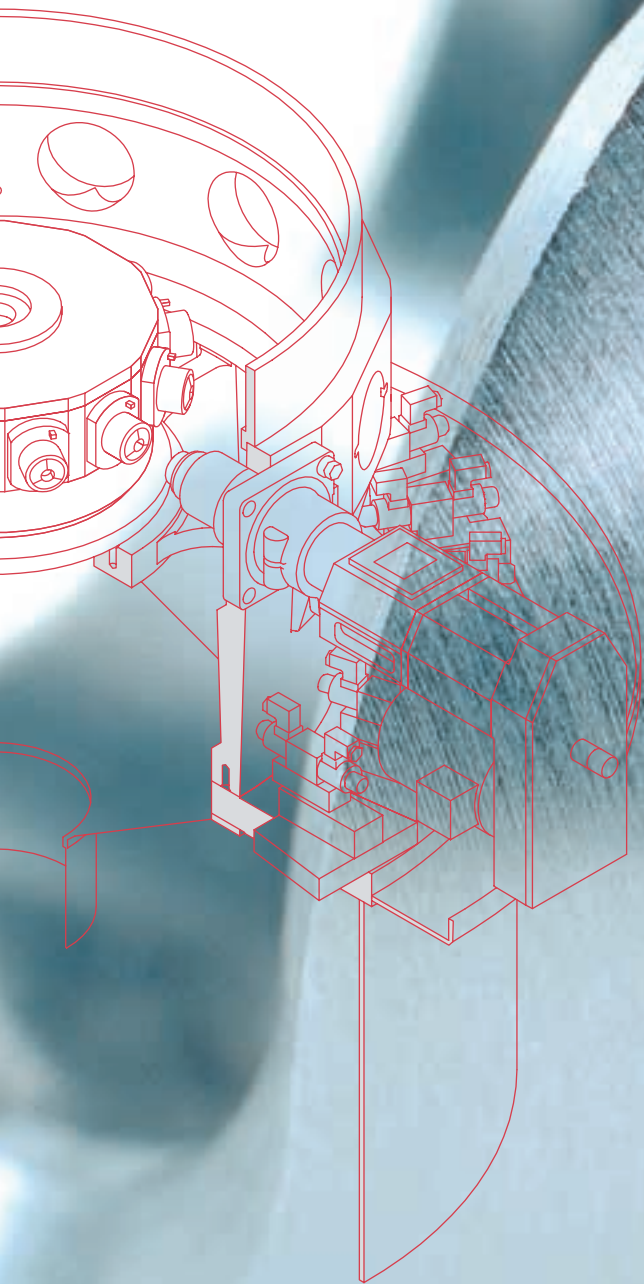

Horizontal transfer system

Complete, double-side machining as part of the process

Optimised for performance

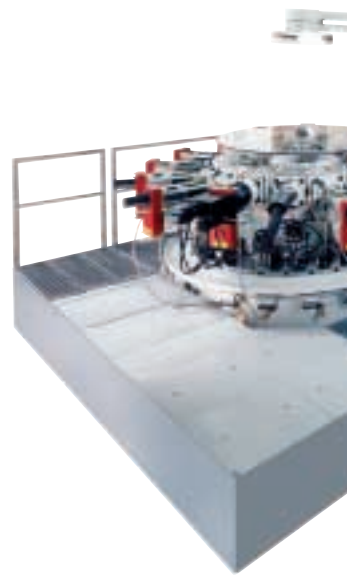
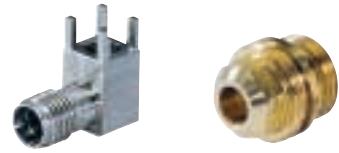
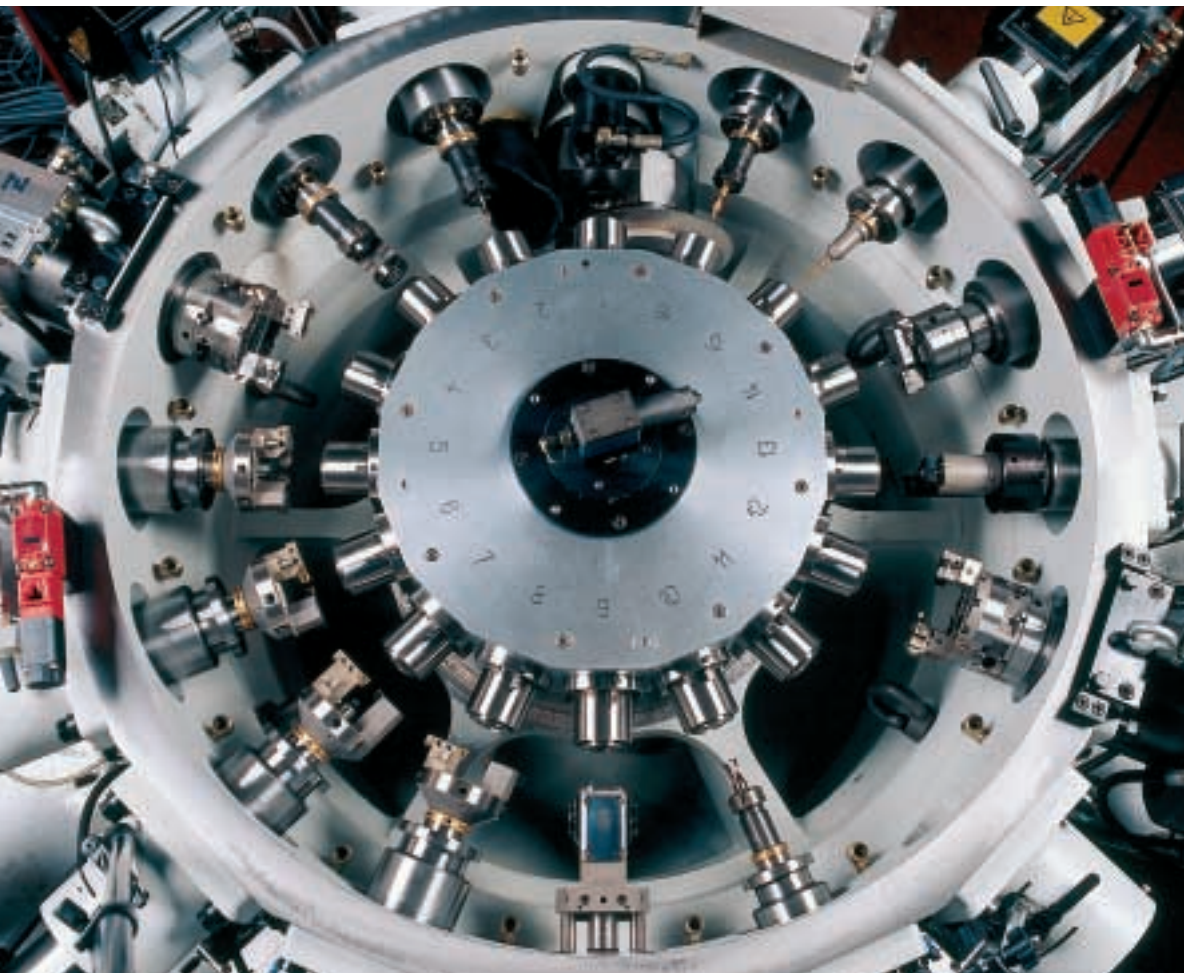

Hydromat® HB: for high flexibility, productivity and economy

Pfiffner has been constructing special, highly-developed machinery for the manufacture of mass-produced workpieces since 1976. These electro-hydraulic, rotary transfer machines can be used for machining from bar stock, coil materials, or parts that are fed in automatically. An intelligent module system offers a high degree of flexibility: The construction and equipping of Pfiffner machines are essentially determined by the workpiece to be machined.

The rotary transfer machines that form the HB and the smaller HW ranges can handle the most demanding machining requirements. The ranges differ in the bar diameter that can be worked and also in the number of units that it is possible to install, but both utilise a completely modular concept. The most varied machining units, control valves, tool heads etc., from the Hydromat® module system can be used in all machine ranges, a feature which assures flexibility for the future.

The Hydromat® HB 45/12 can be equipped with 12 horizontal and 6 vertical machining units, whereas 16 horizontal and 8 vertical stations are possible in



Vertical support
for installing vertical machining units

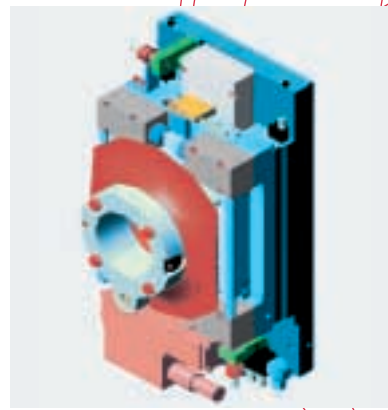

CNC flange
3-D CAD model

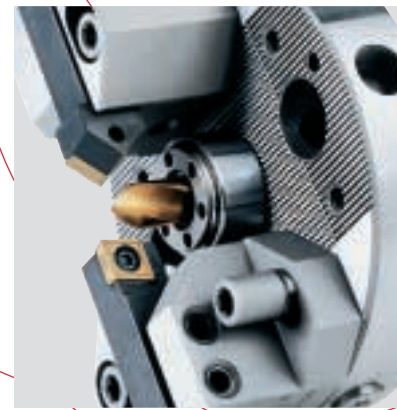

Rotary head

the Hydromat® 32/16 and HB 32-45/16. The machines are fitted with commercially available collet chucks of the B 45 and B 32 types respectively. This allows bar and profile materials of up to 45 mm in diameter and 150 mm in length to be machined.

In spite of being clamped, the workpieces can be worked from both sides. A special turning unit takes out the individual parts and, after turning them through 180°, feeds them back into the chuck.

There is no need for an additional removal unit on completion of the machining: the completed work-

pieces are automatically ejected between the last and first station without having to use a machining station for this process.

As is the case in all Hydromat® machines, all movements, advance speeds, and rapid motions can be infinitely adjusted by means of the hydraulic control valve assigned to the machining unit. In the electrohydraulic model, available as an alternative, the machining units can be comfortably set in operation and monitored via the operating panel. This great degree of flexibility allows the Hydromat® to be quickly and economically re-tooled for new production tasks.



Workpieces produced on the Hydromat® HB



Rotary indexing table with collet chucks

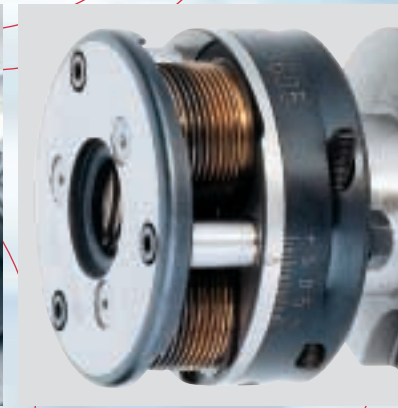

Threading die head for outer threads

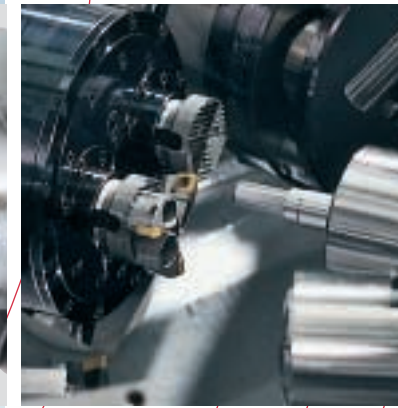

Knurling

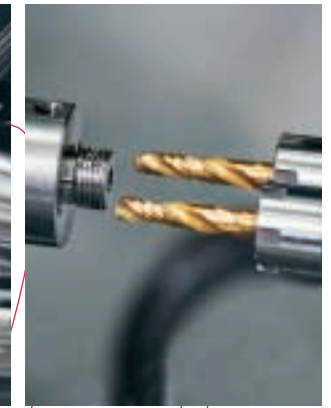

Drilling by means of a multi-spindle drilling head

Machine control system

The consistent modular nature and flexibility of the mechanical systems are also reflected in the machine's electrical control concept. The SIMATIC S7 from Siemens forms the basis of the machine control system. The integrated, Hydromat®-specific user screen facilitates the simple, dialogue-led operation and programming of the machine. Repetitive machining tasks can be stored and called up again when needed, a feature which makes re-tooling much easier. In addition, the unified operating concept of all base machine models reduces training expenditure to a minimum.

The machine's control system concept and design are planned to allow problem-free retooling for extended functionality, such as CNC axes etc. In this process, the digital control system, SINUMERIK 840 D from Siemens, takes over the control of the interpolative machining units. With its integrated ASI bus and Profibus, high performance bus systems are available, onto which customer-specific solutions can be easily mounted at a later date. Teleservice, available as an option, facilitates the fast, remote diagnosis and rectification of malfunctions, a feature which reduces stoppages to a minimum.

		HB 45/12	HB 32/16	HB 32-45/16
Number of stations		12	16	16
Number of machining units	Horizontal max.	12	16	16
	Vertical max.	6	8	8
	Total units	18	24	24
Rotary indexing table	Indexing	12-piece	16-piece	16-piece
	Indexing time	0.7 seconds	0.7 seconds	0.7 seconds
Collet chucks	Number	12	16	16
	Type	B 45	B 32	B 32-45
	Max. clamping Ø	45 mm	32 mm	45 mm
Workpiece	Max. workpiece length	170 mm	150 mm	150 mm
Machine weight inc. bar magazine (4 m)		Approx. 5,800 kg	Approx. 6,500 kg	Approx. 6,500 kg
Machine dimensions		Length 9.8 m	Width 4.0 m	Height 2.9 m

! " # \$\$\$
% " # \$\$\$##
% @!% %% & '
!% %% & '

()
* # \$+ , " -
' .
! " / 0#
% " / 0# ++
% @!% %%
!% %% & '

1 2 3
24 (5 2
4 6.& '
2&7 8 +9
9 4
! " / 0 + \$\$
% " / 0 +
!% %% 2@ & '
!% %% & '

